

The Benefits of Updating Your 3499A/B/C Switching System to the 34980A Switch/Measure Unit

Application Note

Add functionality, streamline your test programs, and reduce the physical test system size by upgrading from your 3499A/B/C to the new 34980A multifunction switch/measure unit.



34980A Mainframe, plug-in modules and terminal cards

This application note will describe differences and advantages of the new 34980A as compared to the 3499A/B/C. The 34980A switch/measure system masters switching, measurement, and control features by offering a superior selection of switch topologies and system control features. A state-of-the-art DMM has been integrated into the 34980A mainframe providing a wide variety of measure capability. The 34980A mainframe also includes standard PC connections and instrument control options for your ease of use. This document will detail the advantages of upgrading your test system using the 34980A in this document.

Measurements

One of the advantages of the new 34980A is its ability to make highly accurate test system measurements. The integration of a high-speed DMM into the mainframe enhances the 34980A switch and control system by providing voltage, current, temperature, frequency, and resistance measurements without using any of the mainframe's available eight slots. The DMM conveniently generates measurement results in selectable engineering units. Eleven different types of measurements can be made and are listed on page 2. The 34980A time-stamped measurement data can be stored

or displayed and analyzed as the measurements are acquired. The 34980A also has configurable high/low limits on each channel that activate an alarm if the input signals are out of the set range. The 34980A's integrated DMM saves you time and money by reducing the number of individual instruments required, and additional cabling for measurements and triggering. In comparison, the 3499A/B/C switch requires an external DMM or other measurement instrument as well as additional wiring to provide the same functionality.

List of 34980A Measurement Capabilities

- Temperature measured with thermocouples, RTDs and thermistors
- DC and AC volts
- 2- and 4-wire resistance
- Frequency and period
- DC and AC current
- 4 alarms for high/low or both limits for each channel
- Digital I/O
- Analog outputs (DAC)

The 34980A mainframe also includes four 2-wire internal analog buses. This is a differentiating 34980A feature and not included with the 3499A/B/C. The analog buses can be used to route measurements directly to the internal DMM or connect the mainframe modules to external instruments. The analog bus can be used to extend modules such as the matrix switch modules, or provide additional signal routing between modules.

Mainframes

The 34980A multifunction switch/measure unit consists of an eight-slot mainframe with an optional DMM. The DMM is mounted directly behind the front panel so it does not require any of the available eight module slots. A choice from 19 different modules can be plugged directly into the eight-slot mainframe.

In comparison, the 3499 family has mainframes in three different sizes: A, B, and C that house five, two, and nine modules respectively. The 3499 family offers a selection of 30 plug-in modules, 13 of which are the earlier generation HP 3488A switch/control unit modules. Since some of the modules were designed for the 3488, and some modules specifically for the 3499, there is duplicate functionality between the modules.

As test systems and capability needs expand there is a call for a greater number of switch channels within one system. The 34980A switch modules are designed for high switching channel count. The 34980A eight-slot mainframe fully loaded with 2-wire multiplexer modules houses a total switch channel count of 560. The 3499C nine-slot mainframe fully loaded with 2-wire multiplexer modules houses a total of 360 switch channels. For a quick summary of the maximum switch channel count for the switch systems mainframes, see Table 1.

Mainframe	Mainframe Size	Number of Module Slots	Maximum Number of Channels (2-wire)
34980A	Full Rack, 3U	8	560
3499B	Rack, 2U	2	80
3499A	Half Rack, 2U	5	200
3499C	Full Rack, 5U	9 (electrical)/14 (physical)	360

Table 1. Max 2-wire Mux channel count per mainframe

Modules

The 34980A implements a superior selection of switch topologies. The 34980A switch topologies are similar to 3499A/B/C switch modules and include multiplexers, matrixes, high-power, general purpose, and RF/microwave switches. However, the 34980A modules have utilized the newest switch technology which enables a higher density of channels per module, and the ability to achieve the faster scan rates with the integrated DMM. The 34980A offers other functionality used in test systems and includes digital I/O, a counter/totalizer and D/A converters. New 34980A functions include a FET multiplexer switch module,

a counter/timer and digital I/O with pattern generator/detector along with digital I/O and D/A converters. The 34980A RF and microwave switch drivers offer functionality for a broader range of RF/microwave switches being used by customers today. The 3499A/B/C does provide a selection of optics switching which is not available with the 34980A. Table 2 shows the 34980A and 3499A/B/C system modules organized by switch and/or measurement type. It is easy to compare and upgrade from the 3499A/B/C switch modules to the new 34980A switch modules as well as add new switch, measurement and control capabilities.

Benefits of the new 34980A modules vs 3499A/B/C modules

- Increased channel count per module with the same switch reliability
- Increased drivability for various RF/ μ Wave switches
- High speed FET multiplexer
- Reed matrix switch
- Switch/attenuator driver
- Counter/timer
- High Speed Digital I/O with memory
- Analog output with waveform capabilities
- Breadboard module with +5 V, +12 V

With so many different types of switch modules to choose from, you can easily identify the modules from Table 2 that provide the best solution to meet your test application needs. For detailed module specifications, please refer to the product data sheets available at these web locations: <http://www.agilent.com/find/34980A> and <http://www.agilent.com/find/3499>



3499A/B Mainframe and plug-in modules

Table 2. Direct comparison of 34980A and 3499 modules

Module Type	34980A	3499A/B/C
Multiplexer	34921A 40 Ch armature 300 V 1 A	N2260A 40 Ch armature 200 V 1 A
	34922A 70 Ch armature 300 V 1 A	N2266A 40 Ch reed 200 V 0.5 A
	34923A 40 Ch reed 200 V 0.5 A	N2270A 10 Ch 1000 V 1 A
	34924A 70 Ch reed 200 V 0.5 A	44470A 10 Ch armature 250 V 2 A
	34925A 40 Ch FET +/-80 V 0.5 A	44470D 20 Ch armature 250 V 2 A
General Purpose	34937A 28 Ch, 1 A and 4 Ch, 5 A	N2261A 40 Ch
	34938A 20 Ch, 5 A	N2267A 8 Ch, 8 A
		44471A 10 Ch
		44471D 20 Ch
		44477A 7 Ch SPDT (Form C)
Matrix	34931A Dual 4x8 armature 300 V 1 A	N2262A 4x8 armature 200 V 1 A
	34932A Dual 4x16 armature 300 V 1 A	44473A 4x4 armature 250 V 2 A
	34933A Dual 4x8 reed 80 V 0.5 A	
Digital I/O	See multifunction 34950A, 34952A	N2263A 32-bit TTL
		44474A 16-bit TTL
Multifunction	34952A 32-bit Digital I/O with 2 Ch DAC and Counter/Timer	N2264A 12 GP, 3 GP 5 A, 16-bit Dig I/O
	34950A 64-bit Digital I/O with Pattern Generator/Detector	N2265A 4x4 matrix, 16-bit Dig I/O N2269A 2 DAC, 16-bit Dig I/O
Fiber-Optic Multiplexer		N2280A Quad 1x2 N2281A Dual 1x4 N2282A Single 1x8
RF & Microwave	34941A Quad 1x4 RF 3 G 50 Ω, SMA	N2268A Dual 1x4 3.5 G 50 Ω
	34946A 4 G/20 G 50 Ω, 2 SPDT SMA (N1810TL)	N2272A Single 1x9 1 G 50 Ω
	34947A 4 G/20 G 50 Ω, 3 SPDT, SMA (N1810UL)	N2276A Dual 1x6 20 G 50 Ω (87106B/4B)
		44472A Dual 1x4 300 M 50 Ω
		44478A Dual 1x4 1.3 G 50 Ω
		44476A Triple 1x2 18 G 50 Ω (8762B)
	34942A Quad 1x4 RF 1.5 G 75 Ω, mSMB	44478B Dual 1x4 1.3 G 75 Ω
	34945A μwave Switch/Attn Driver 32 SPDT or 8 attenuators	N2276B Relay Driver (2 switches)
	The following μwave switches and attenuators are supported with the distribution ¹ boards;	Choose from switches;
	N181x series SPDT switches	87104A/B/C
876X series SPDT switches	87106A/B/C	
87104x/106x multi-port switches	also drive two external attenuators	
87606x series matrix switches	84904/6/7/K/L	
8722x transfer switches	44476B Relay Driver (2 switches)	
849x series attenuators	Choose from switches;	
8490x series attenuators	8762A/B/C/F	
Generic screw terminal connections	8763B/C	
Third-party switches (screw terminals)	8764B/C	
DAC	34951A Quad 16-bit D/A Converter	See multifunction
Breadboard	34959A +12 V, +5 V	44475A 5.5 V

User Interface

The 34980A offers the most modern instrument I/O options for interfacing a controller PC with the switch system: GPIB, USB and LAN. All three Input/Output interface connections come standard with the 34980A mainframe. If you choose to modify or upgrade your test system I/O, the 34980A is system ready.

You can also easily control the 34980A without connecting to a PC by pressing the front-panel buttons, an advantage when first setting up or troubleshooting a system.

Upgrading your test system from using the 3499A/B/C GPIB to the 34980A GPIB, or newer USB or LAN is quick and easy. If you have used I/O Config from the Agilent I/O Libraries to set your GPIB instrument connection, you would use the same I/O Config to set up your LAN or "TCPIP" instrument connection. Retrieve the LAN, TCPIP address from your instrument and enter it into I/O Config. When you address your instrument in a program, it will look similar to; TCPIP0::9::INSTR. For more information on connecting to Agilent instruments you can access the Agilent Technologies USB/LAN/ GPIB Interfaces Connectivity Guide at www.agilent.com/find/connectivity

With LAN, the instrument can be located closer to the device under test without worrying about the distance to the PC. A USB to instrument connection is even easier. The computer automatically detects instruments that are USB ready. If you are currently using the 3499A/B/C RS232 interface, it is recommended to upgrade to the 34980A GPIB, USB or LAN interface to achieve optimal data transfer rates.

Instrument Control (Programming)

The 34980A and 3499A/B/C can both be controlled locally from the front panel, or by sending either instrument or driver commands from a PC for remote control. The 34980A's instrument commands and drivers are based on modern standards such as SCPI (standard commands for programmable instruments) and IVI-C and IVI COM drivers. The SCPI instrument commands of the 34980A are similar to the 3499A/B/C's but they are not interchangeable. A comparison of the commands is provided in appendix A. The 34980A's IVI-C

and IVI-COM drivers are similar to *Plug&Play* drivers, the 3499A/B/C's *Plug&Play* driver for example, but include improvements. The IVI (Interchangeable Virtual Instruments) driver specification was built upon the *Plug&Play* driver specification but adds the capabilities provided by the Microsoft ActiveX technologies which simplify instrument interchangeability, and product performance. The 34980A also includes many new commands for the operation of the embedded DMM. A 34980A Web interface provides a new easy way to communicate via LAN with the instrument.

Table 3 shows a summary of the programming control options available for the 3499A/B/C and the 34980A. There is similarity between the instrument commands, however, the 34980A has evolved to use the most modern and widely accepted instrument command standards.

Table 3. Control Options for 3499A/B/C and 34980A

	3499A/B/C	34980A
Front Panel Buttons	•	•
3488 Legacy Commands	•	
SCPI Commands	•	•
Plug & Play driver	•	
IVI COM driver	•	•
IVI-C driver		•
LabVIEW driver		•
Web Interface		•

Listed below are each of the many ways available to communicate and control the 34980A, the communication options and their description.

Web Page Interface

The 34980A comes with a built-in detailed instrument web page that allows you to remotely connect and communicate with the mainframe and installed modules. You establish a LAN connection, either directly between the 34980A and PC, or from the 34980A to an existing Local Area Network. The instrument Web page resides on the 34980A and can be accessed using a standard web browser such as Netscape or Internet Explorer on a PC. Just type the IP address into the web browser. The web interface allows you to select any of the installed modules and view the current configuration, change settings, make measurements, and makes it easy to troubleshoot or debug the switch/measure system. The instrument web interface also allows you to check the current status of the instrument by viewing the error queue, calibration status and the accumulated module switch closures.

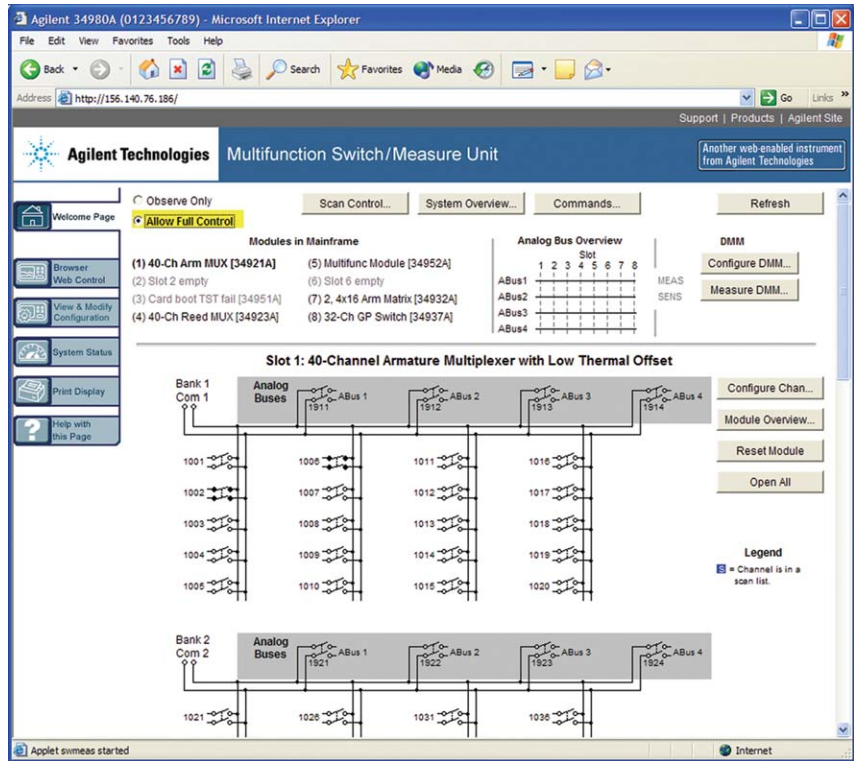

Web interface display for 34921A MUX Switch module

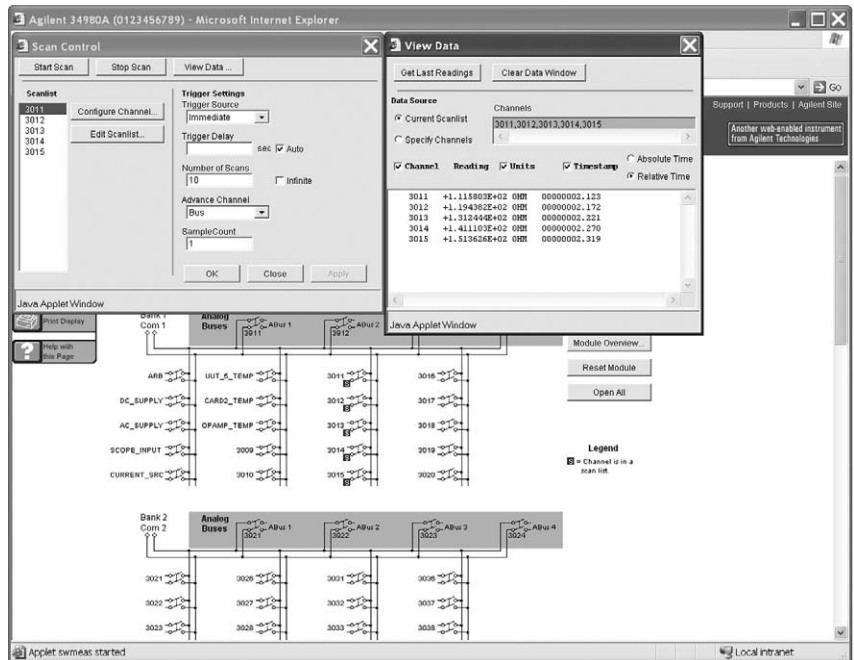

Web interface display of scanned measurements

SCPI Commands

The 34980A can be programmed using SCPI commands or the IEEE standard commands. Configuration, measurements and system control of the mainframe and modules are easily achieved using these instrument commands.

One difference between instrument commands for the 3499A/B/C and the 34980A relates to addressing specific channels in the system. Table 4 shows an example difference in 3499A/B/C switch control commands compared to 34980A commands. Notice the 34980A uses four digits to address the module slot number and channel(s) rather than only

three digits as the 3499A/B/C uses. Also, for the 3499A/B/C the [ROUTE] in the command structure is optional, where with the 34980A it is required.

The 34980A offers new measurement and module capabilities such as counter/timer and digital I/O with pattern generator/detector that use commands unique to their functionality. Appendix A includes a list of the 34980A and 3499A/B/C commands as well as direct comparisons of the commands.

IVI-C, IVI COM and LabVIEW instrument drivers

34980A IVI-C, IVI COM and LabVIEW instrument drivers are available for simplified programming. If you currently program using *Plug&Play* drivers, the IVI-C driver is similar and can be used to program in the same way. The IVI COM driver conforms to the most modern IVI COM instrument driver standard and can be used in any programming environment. LabVIEW programmers are able to use the 34980A LabVIEW instrument driver for their graphical programming environment.

Table 4. Command comparisons

34980A	3499A/B/C
Close channel 10 on the module in slot 3	
ROUTE:CLOS (@3010)	[ROUTE:]CLOS (@310)
Scan channels 0 through 40 on the module in slot 1	
ROUTE:SCAN (@1001:1040)	[ROUTE:]SCAN (@100:140)

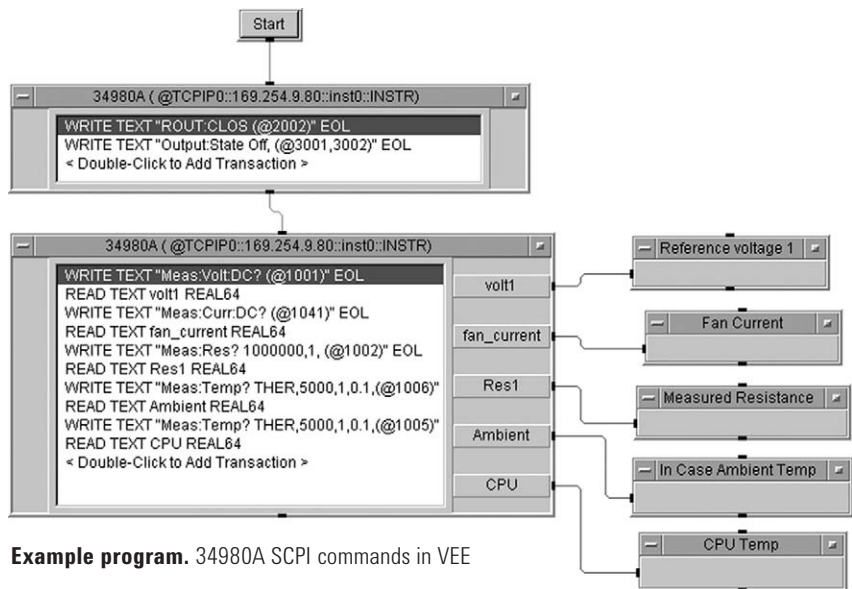

Example program. 34980A SCPI commands in VEE

Scan Feature

The scan feature is a sequence of alternating switch closures and measurements. This feature is provided by both the 34980A and a 3499A/B/C combined with a DMM or other measurement instrument. The 34980A increases the measurement scan abilities and offers more than twice the number of scanned channels within one scan list compared to the 3499A/B/C as seen here.

Single Scan List Size:

34980A Up to 560
2-wire channels
or
Up to 640
1-wire channels

3499A/B/C Up to 200 channels
and/or bits

Although the 34980A scan feature can be used with either the internal DMM or with an external instrument, using the integrated DMM provides a faster and more efficient scan rate. The integrated DMM eliminates the need for external instrument triggers and wiring. The 3499A/B/C scan list requires the use of instrument triggers to work with an external DMM or other measurement instrument. Each switch module is rated with individual switch scan rates. A comparison of the scan rates for both systems Multiplexer and Matrix switch modules is shown in Table 5 below.

Another advantage the 34980A system has over the 3499A/B/C system is its ability to store measurement readings. When the 34980A internal DMM is used, up to 500,000 time stamped readings can be stored in volatile memory.

The 3499A/B/C cannot store readings but does offer more scan configurability. For example, once a 3499A/B/C scan list is set up, the user can select an arm source, a trigger source, the number of sweeps, and the delay time for each individual channel within the scan list.

Table 5. 34980A and 3499A/B/C multiplexer and matrix module scan rates

Module Type	34980A	Scan Rate	3499A/B/C	Scan Rate
	Modules		Ch/s	
Multiplexer	34921A 40 Ch armature	100	N2260A 40 Ch armature	80
	34922A 70 Ch armature	100	N2266A 40 Ch reed	350
	34923A 40 Ch reed	500	N2270A 10 Ch	100
	34924A 70 Ch reed	500	44470A 10 Ch armature	43
	34925A 40 Ch FET	1000	44470D 20 Ch armature	43
Matrix	34931A Dual 4x8 armature	100	N2262A 4x8 armature	80
	34932A Dual 4x16 armature	100	44473A 4x4 armature	43
	34933A Dual 4x8 reed	500		

Monitor Feature

The 34980A monitor feature allows you to monitor readings acquired by the switch/measure system. You can also monitor readings acquired with the 34980A internal DMM. To monitor a measurement from the front panel, simply select the channel and press either the Measure [DMM] or [Channel] button to see a continually updated channel output or state on the front display. For programs, use the ROUTe:MONitor:DATA? Command. The command reads the data from the channel currently selected by the Monitor function. One reading is displayed for each monitor command. The Web interface can also be used to monitor a channel measurement.

The 3499A/B/C monitor feature allows users to continuously monitor a selected switch or module status from the front display. A channel monitor can be set up using the front panel buttons or instrument commands. The 3499A/B/C monitor output can be a specific switching channel, a digital I/O port or the state of all switches or digital I/O on one plug-in module. The 3499A/B/C allows a single channel to be monitored continuously even during an instrument scan.

Stored State Feature

The 34980A is also able to store/recall up to six (0 through 5) instrument setups. A stored setup state can be automatically recalled at any time, even during a power up state. The stored state feature contains the state of the plug-in modules including channel configurations, scanning setups, alarm values, and Mx + B scaling values. Location 0 is typically used for the factory reset and power down state, but can also be programmed with a new setup.

The 3499A/B/C is able to store and recall up to 50 instrument setup states with revision 4.0. The instrument setups include the status of relay channels, and/or the static digital I/O state, module configuration, and scanning setups (scan lists, arm count, arm source, etc.). The 3499A/B/C is not able to automatically power up in a stored state.



Switch and Measurement Connections

Most often, test systems must be flexible enough to be easily moved to a new location or modified for different devices under test. Having a removable wiring terminal block or a pre-wired cable is optimal in these situations. The module's terminal and/or cable can simply be removed and replaced with a different terminal for the new test configuration. This prevents the need to rewire the same terminal each time for different applications. Fortunately, both the 34980A and 3499A/B/C provide the removable terminals and pre-wired cables so changing your test system wiring from the 3499A/B/C to the 34980A is fairly simple.

The 34980A offers the ability to use either standard Dsub 50 and Dsub 78 connectors/cables, detachable terminal cards or mass interconnect connections. The RF and microwave modules include standard connectors

such as SMA and SMB. The 34980A cables (Dsub 50 and Dsub 78) are low cost and readily available from many sources. The detachable screw terminal blocks are easy to wire and include built-in cable strain relief. The screw terminals attach to the switch modules with a secure latching mechanism for ease of use and improved connection reliability. No tools are required to easily connect and disconnect the wired terminals. The 3499 terminals are secured to the module and housing by screws at the end of the terminals and require a screwdriver to remove or replace.

For more complex test system wiring, mass interconnect (one location in a system where the switch, instruments and DUT are interconnected) is made easy by using solutions provided by connection experts. The standard Dsub 50 and Dsub 78 connectors make it faster and easier for mass interconnect suppliers to provide a test system wiring solution. The easy to use connections facilitate time and cost savings for test systems using the 34980A.

The 34980A terminal wiring and cables are different from that of the 3499A/B/C. However, they offer a better solution to test system interface due to the use of highly reliable standard connectors and low cost cables.

Refer to Table 2 for the modules that have optional terminal blocks or the 34980A data sheet for specific module wiring connection details: <http://www.agilent.com/find/34980A>.

The 3499A/B/C offers removable screw terminal blocks for many of the modules and also an option for pre-wired DIN96 to quad D25, or dual D50 cables. Some of the modules such as the optics, microwave and RF modules include the SMA or BNC terminals for application specific connections. Refer to Table 2 for modules that include terminals.



34980A Modules and Std DSub 50/78 connectors



3499A/B/C Modules and Terminals

Summary

Although the 3499A/B/C switch/control system has been a great addition to many test systems, the new 34980A now offers an even better module selection plus measurement capability, standard PC connections for communication, and is easy to connect to modules. The wide offering of plug-in modules for the 34980A enables you to select a configuration for your specific application needs.

Features that differentiate new 34980A:

- FET switches for long life, high speed measurement scans and the latest in technology armature and reed relays for both multiplexer and matrix switching
- Analog bus for joining modules, connecting to external instruments, accessing internal DMM.
- Up to 5 A general purpose switch addresses the most common high power and device control applications.
- Bread board with +12 V and +5 V supplies for more design flexibility.
- Integrated DMM and measurement capability save you time versus programming with an external measurement instrument, and money with the switch and DMM in one instrument.
- Up to 1000 readings/s scan rate for higher speed applications
- GPIB and new USB and LAN interfaces provide flexibility, lower cost, higher data transfer rates, and are the emerging trend of choice of interfaces.
- Up to 70 Ch per module offer higher density solutions
- Standard module connectors & cables offer an easy connection and for mass interconnect solutions.
- Screw terminals with latching mechanisms are easy to remove and replace and securely fastened when in use.
- Web interface to quickly and easily test or debug the test system switching.
- Large memory buffer for acquired measurements.

There are a few specialized features the 3499 offers that are not available with the new 34980A. It is good to be aware of the differences as you upgrade to the newer system.

3499A/B/C differentiating features

- 4-dig I/O ports built into mainframe doesn't require a module
- Fiber-optic modules
- 1000 V multiplexer module

The 34980A switch/measure unit can be used in the same applications as the 3499A/B/C including design verification, functional test and data acquisition applications. It can also be used in many new applications such as for data logging, as a data acquisition system and/or as a switch system. It can even provide a solution for applications requiring transducer-based measurements such as thermocouple or strain. The 34980A offers a great switch, measurement and test system control solution at a great value.

Appendix A – Command Reference/Comparison

34980A Commands	3499A/B/C Commands
ABORt	ABORt ARM :SOURce BUS EXTernal IMMEDIATE TIMer MIX/HOLD :SOURce? :COUNT <number> MIN MAX :TIMer <seconds> MIN MAX :TIMer?
CALCulate :AVERage:AVERage? :AVERage:CLEar :AVERage:COUNT? :AVERage: MAXimum? :AVERage:MAXimum:TIME? :AVERage:MINimum? :AVERage:MINimum:TIME? :AVERage:PTPeak? :LIMit:LOWer :LIMit:LOWer? :LIMit:LOWer:STATe :LIMit:LOWer:STATe? :LIMit:UPPer :LIMit:UPPer? :LIMit:UPPer:STATe :LIMit:UPPer:STATe? :SCALE:GAIN :SCALE: GAIN? :SCALE:OFFSet :SCALE:OFFSet? :SCALE: OFFSet:NULL :SCALE: STATE :SCALE: STATE? :SCALE:UNIT :SCALE: UNIT?	
CALibration :COUNT? :LFRequency? :SECure:CODE SECure:STATe :SECure:STATe? :SETup :SETup? :STRing :STRing? :VALue :VALue?	
CALibration?	
CONFigure	CONFigure :EXTernal[:TRIGger] :SOURce :SOURce? [:OUTPut] 0 1 OFF ON [:OUTPut]?

34980A Commands (cont'd.)

3499A/B/C Commands (cont'd.)

```

:CURRent:AC
:CURRent[:DC]
:DIgital:STATe
:DIgital:WIDTh
:FREQuency
:FRESistance
:PERiod
:RESistance
:TEMPerature
:TOTalize
[:VOLTage]:AC
[:VOLTage][:DC]
CONFigure?
DATA
:LAST?
:POINts:EVENt:THReshold
:POINts:EVENt:THReshold?
:POINts?
:REMOve?
DIAGnostic
:DMM:CYCLes:CLEar
:DMM:CYCLes?
:RELAy CYCLes:CLEar
:RELAy:CYCLes?
DISPlay
[:STATe]
[:STATe]?
:TEXT
:TEXT ?
:TEXT:CLEar
FETCh?
FORmat
:BORder
:READing:ALARm
:READing:ALARm?
:READing:CHANnel
:READing:CHANnel?
:READing:TIME
:READing:TIME?
:READing:TIME:TYPE
:READing:TIME:TYPE?
:READing:UNIT
:READing:UNIT?
INITiate
INSTrument
:DMM:CONNect
:DMM:DISConnect
:DMM:INSTalled?
:DMM[:STATe]
:DMM[:STATe]?
MEASure

DIAGnostic
[:RELAy]:CYCLes:CLEar
[:RELAy]:CYCLes?
[:RELAy]:CYCLes:CLEar
[:RELAy]:CYCLes?
[:RELAy]:CYCLes:MAX?
:DISPlay[:INFORmation]
:DISPlay:STATe?
:MONitor
:MONitor?
:SPEEK?
:SPOKE

FETCh?

INITiate

```

34980A Commands (cont'd.)

3499A/B/C Commands (cont'd.)

```

:CURRent:AC?
:CURRent[:DC]?
:DIgital[:<width>]?
:DIgital[:BYTE]:BIT?
:FREQuency?
FRESistance?
:PERiod?
:RESistance?
:TEMPerature?
:TOTalize?
[:VOLTage]:AC?
[:VOLTage][:DC]?
MEMory
:STATe:CATalog?
:STATe:DElete
:STATe:NAME
:STATe:NAME?
:STATe:RECall:AUTO
:STATe:RECall:AUTO?
:STATe:RECall:SElect
:STATe:RECall:SElect?
:STATe:VALid?
OUTPut
:ALARm<n>:CLEar
:ALARm:MODE
:ALARm:MODE?
:ALARm:SLOPe
:ALARm: SLOPe?
:ALARm<n>:SOURce
:ALARm<n>:SOURce?
[:STATe]
R?
READ?
ROUTE
:CHANnel:ADVance:SOURce
:CHANnel:ADVance:SOURce?
:CHANnel:DELay
:CHANnel:DELay?
:CHANnel:DELay:AUTO
:CHANnel:DELay:AUTO?
:CHANnel:FWIRE
:CHANnel:FWIRE?
:CHANnel:LABel:CLEar:MODule
:CHANnel:LABel[:DEFine]
:CHANnel:VERify[:STATe]
:CLOSE
:CLOSE?
:MODule:BUSY?
:MODule:WAIT
:MONitor[:CHANnel]
:MONitor[:CHANnel]ENABLE
:MONitor:DATA?
:MONitor:MODE
:MONitor:STATe
:MONitor:STATe?
:OPEN
:OPEN?
:OPEN:ABUS
:OPEN:ALL
:OPERation:OVERlap[ENABLE]
[ROUTe:]
[CHANnel:]DELay
[CHANnel:]DELay?
CLOSE
CLOSE?
OPEN
OPEN?

```

34980A Commands (cont'd.)

3499A/B/C Commands (cont'd.)

:SCAN
 :SCAN:ADD
 :SCAN:REMove
 :SCAN:SIZE?

SCAN:SIZE?
 SCAN[:LIST]?
 SCAN[:LIST]
 SCAN CLear
 CPAir
 CPAir?
 FUNCtion
 FUNCtion?

SAMPlE

:COUNT
 :COUNT?

SENSe

SENSe

:DIGital

:DATA:BIT?
 :DATA[:<BYTE | WORD | LWORD>[:VALue]?
 :DATA[:<BYTE | WORD | LWORD>:BLOCK?
 :DATA[:<BYTE | WORD | LWORD>:TRACE
 :TRACe[:DATA]?

:CURRent:AC

:BANDwidth
 :BANDwidth?
 :RANGe
 :RANGe?
 :RANGe:AUTO
 :RANGe:AUTO?

:CURRent[:DC]

:APERture:ENABled?
 :APERture
 :NPLC
 :NPLC?
 :RANGe
 :RANGe?
 :RANGe:AUTO
 :RANGe:AUTO?
 :RESolution
 :RESolution?
 :ZERO:AUTO

:DIGital:DATA[:<width>]?

:DIGital:DATA[BYTE]:BIT?

:FREQuency

:APERture
 :APERture?
 :RANGe:LOWer
 :RANGe:LOWer?
 :VOLTage:RANGe
 :VOLTage:RANGe?
 :VOLTage:RANGe:AUTO
 :VOLTage:RANGe:AUTO?

:FRESistance

:APERture
 :APERture:ENABled?
 :NPLC
 :NPLC?
 :OCOMpensated
 :OCOMpensated?
 :RANGe
 :RANGe?
 :RANGe:AUTO

34980A Commands (cont'd.)**3499A/B/C Commands (cont'd.)**

```

:RANGe:AUTO?
:RESolution
:RESolution?
:ZERO:AUTO
:FUNction
:FUNction?
:PERiod:APERture
:PERiod:VOLTage:RANGe
:VOLTage:RANGe?
:VOLTage:RANGe:AUTO
:VOLTage:RANGe:AUTO?
:PERiod:ZERO:AUTO
:RESistance:APERture
:APERture?
:ALPERture:ENABled?
:NPLC
:NPLC?
:OCOMpensated
:OCOMpensated?
:RANGe
:RANGe?
:RANGe:AUTO
:RANGe:AUTO?
:RESolution
:RESolution?
:ZERO:AUTO
:TEMPerature:APERture
:APERture:ENABled?
:NPLC
:NPLC?
:TRANsducer:Tcouple:IMPedance:AUTO
:Tcouple:CHECK
:RJUNction
:RJUNction:TYPE
:TYPE
:TRANsducer:TYPE
:FRTD:RESistance
:FRTD:TYPE
:RTD:RESistance
:RTD:TYPE
:THERmistor:TYPE
:ZERO:AUTO
:RJUNction?
:TOTALize:CLEar:IMMEDIATE
:DATA?
:SLOPe
:THReshold[:MODE]
:TYPE
:VOLTage
:AC:BANDwidth
:AC:BANDwidth?
:AC:RANGe
:AC:RANGe?
:AC:RANGe:AUTO
:AC:RANGe:AUTO?
[:DC]:APERture
[:DC]:APERture?
[:DC]:APERture:ENABled?
[:DC]:IMPedance:AUTO
[:DC]:NPLC

```

34980A Commands (cont'd.)

[:DC]:NPLC?
 [:DC]:RANGe
 [:DC]:RANGe?
 [:DC]:RANGe:AUTO
 [:DC]:RANGe:AUTO?
 [:DC]:RESolution
 [:DC]RESolution
 [:DC]:ZERO:AUTO
 [:DC]:ZERO:AUTO?

SOURce

:CURRent[:LEVel]
 :CURRent[:LEVel]?

:DIGital:DATA[:<width>]
 :DIGital:DATA[BYTE]:BIT
 :DIGital:STATe?
 :FUNction:CLOCK:EXternal:DIVisor
 :CLOCK[INternal]:PERiod
 :CLOCK:SOURce
 :CURRent:GAIN
 :CURRent:OFFSet
 :ENABLE
 :FREQuency
 :HALT
 :STATus?
 :TRACe:NCYCles
 :TRACe[NAME]
 :TRACe:SINdex
 :TRIGger:IMMEDIATE
 :TRIGger:SOURce
 :VOLTage:GAIN
 :VOLTage:OFFSet

:MODE
 :MODE?
 :VOLTage[:LEVel]
 :VOLTage[:LEVel]?

STATus

:ALARm:CONDition?
 :ALARm:ENABLE

3499A/B/C Commands (cont'd.)

SOURce

:DIGital
 :MODE
 :MODE?
 :CONTRol:POLarity
 :CONTRol:POLarity?
 :FLAG:POLarity
 :FLAG:POLarity?
 :IO:POLarity
 :IO:POLarity?
 :DATA[:<BYTE | WORD | LWORD>]:POLarity
 :DATA[:<BYTE | WORD | LWORD>]:POLarity?
 :DATA:BIT
 :DATA[:<BYTE | WORD | LWORD>][:VALue]
 :DATA[:<BYTE | WORD | LWORD>]:BLOCK
 :DATA[:<BYTE | WORD | LWORD>]:TRACE
 :TRACe:DEFine
 :TRACe:DEFine?
 :TRACe:CATalog?
 :TRACe[:DATA]
 :TRACe:DELete[:NAME]
 :TRACe:DELete:ALL

STATus

34980A Commands (cont'd.)

3499A/B/C Commands (cont'd.)

```

:ALARm:ENABle?
:ALARm[:EVENT]?
:MODule:ENABle
:MODule:EVENT?
:MODule:SLOT[n]:CONDition?
:MODule:SLOT[n]:ENABle
:MODule:SLOT[n][:EVENT]?
:OPERation:CONDition?
:OPERation:ENABle
:OPERation:ENABle?
:OPERation[:EVENT]?
:PRESet
:QUEStionable:CONDition?
:QUEStionable:ENABle
:QUEStionable:ENABle?
:QUEStionable[:EVENT]?

SYSTem
:ABUS:INTerlock:SIMulate
:ALARm?
:BEEPer
:BEEPer:STATe?
:CDEscription?
:COMMunicate:ENABle
:GPIB:ADDResS
:LAN:AUTOip
:LAN:BSTatus?
:LAN:CONTRol?
:LAN:DHCP
:LAN:DNS
:LAN:DOMain
:LAN:GATEway
:LAN:HISTory?
:LAN:HISTory:CLEar
:LAN:HOSTname
:LAN:IPADdress
:LAN:KEEPalive
:LAN:MAC?
:LAN:SMAsk
:LAN:TELNet:PRoMpt
:LAN:TELNet:WMESsage

:CPON
:CTYPE?
:DATE
:DATE?
:ERRor?
:KLOCK:EXCLude
:KLOCK:EXCLude?
:KLOCK[:STATe]
:KLOCK[:STATe]?
:LOCK:OWNer?
:LOCK:RELease
:LOCK:REQUest?
:MODule?
:MODule:PFail:JUMPer:AMP5?
:MODule:WIRE:MODE
:MODule:TEMPerature?
:PRESet
:SECurity:IMMEDIATE
:TIME
    
```

```

:OPERation:CONDition?
:OPERation:ENABle
:OPERation: ENABle?
:OPERation[:EVENT]?
:PRESet

SYSTem
    
```

```

:CPON
:CTYPE?

:ERRor?
    
```

34980A Commands (cont'd.)

3499A/B/C Commands (cont'd.)

:TIME?
:TIME:SCAN?
:VERSion?

:VERSion?
:LOCal
:REMote
:RWLock
:STATe:DElete

TRACe:CATalog?
[:DATA]
[:DATA]:DAC
[:DATA]:FUNction
:DELeTe:ALL
:DELeTe[:NAME]
:FREE?
:POINts?

TRIGger

:COUnT
:COUNT?
:DELay
:DELay?
:DELay:AUTO
:DELay:AUTO?
:SOURce
:SOURce?
:TIMer
:TIMer?

TRIGger

[:IMMediate]

:SOURce
:SOURce?
:TIMer
TIMer?

UNIT

:TEMPerature
:TEMPerature?

IEEE-488.2 Common Commands

*CLS
*ESE *ESE?
*ESR?
*IDN?
*OPC *OPC?
*PSC *PSC?
*RCL
*RST
*SAV
*SRE *SRE?
*STB?
*TRG
*TST?
*WAI

IEEE-488.2 Common Commands

*CLS
*OPC *OPC?



Agilent Email Updates

www.agilent.com/find/emailupdates

Get the latest information on the products and applications you select.



Agilent Direct

www.agilent.com/find/quick

Quickly choose and use your test equipment solutions with confidence.



www.agilent.com/find/open

Agilent Open simplifies the process of connecting and programming test systems to help engineers design, validate and manufacture electronic products. Agilent offers open connectivity for a broad range of system-ready instruments, open industry software, PC-standard I/O and global support, which are combined to more easily integrate test system development.



LXI is the U.S. registered trademark of the LXI Consortium.

Remove all doubt

Our repair and calibration services will get your equipment back to you, performing like new, when promised. You will get full value out of your Agilent equipment throughout its lifetime. Your equipment will be serviced by Agilent-trained technicians using the latest factory calibration procedures, automated repair diagnostics and genuine parts. You will always have the utmost confidence in your measurements.

Agilent offers a wide range of additional expert test and measurement services for your equipment, including initial start-up assistance onsite education and training, as well as design, system integration, and project management.

For more information on repair and calibration services, go to

www.agilent.com/find/removealldoubt

www.agilent.com

For more information on Agilent Technologies' products, applications or services, please contact your local Agilent office. The complete list is available at:

www.agilent.com/find/contactus

Phone or Fax

United States:

(tel) 800 829 4444
(fax) 800 829 4433

Canada:

(tel) 877 894 4414
(fax) 800 746 4866

China:

(tel) 800 810 0189
(fax) 800 820 2816

Europe:

(tel) 31 20 547 2111

Japan:

(tel) (81) 426 56 7832
(fax) (81) 426 56 7840

Korea:

(tel) (080) 769 0800
(fax) (080) 769 0900

Latin America:

(tel) (305) 269 7500

Taiwan:

(tel) 0800 047 866
(fax) 0800 286 331

Other Asia Pacific Countries:

(tel) (65) 6375 8100
(fax) (65) 6755 0042
Email: tm_ap@agilent.com

Revised: 09/14/06

Product specifications and descriptions in this document subject to change without notice.

Microsoft, Visual Studio and Windows are U.S. registered trademarks of Microsoft Corporation.

© Agilent Technologies, Inc. 2006
Printed in USA, November 27, 2006
5989-1581EN



Agilent Technologies